

承认书

SPECIFICATION FOR APPROVAL

Customer: _____

Description: SMD LED

Model: BDS-1106SURZGQBC

No.: SD0013

Date: 2006-03-27

Enclosure is the specification

SHENZHEN BOND OPTOELECTRONICS CO.,LTD			
Production Dept.	Quality Dept.	Engineering Dept.	Marketing Dept.

APPROVED SIGNATURES			

Address: B501, Seat 5, YongLeXinCun, Nanshan District, Shenzhen, China

电话 Tel: 0086-755-26685446

传真 Fax: 0086-755-26822679

E-mail: Kevin@bond-led.com

Website: <http://www.bond-led.com>

BDS-1106SURZGBC
FULL COLOR

Features

- 1)3.0x1.5mm SMT LED, 0.7mm THICKNESS.
- 2)LOW POWER CONSUMPTION.
- 3)WIDE VIEWING ANGLE.
- 4)IDEAL FOR BACKLIGHT AND INDICATOR.
- 5)VARIOUS COLORS AND LENS TYPES AVAILABLE.
- 6)PACKAGE: 2000PCS/REEL.

Description

The full source color devices are made with InGaN γ InGaAlP and InGaN Light Emitting Diode

Package Dimensions

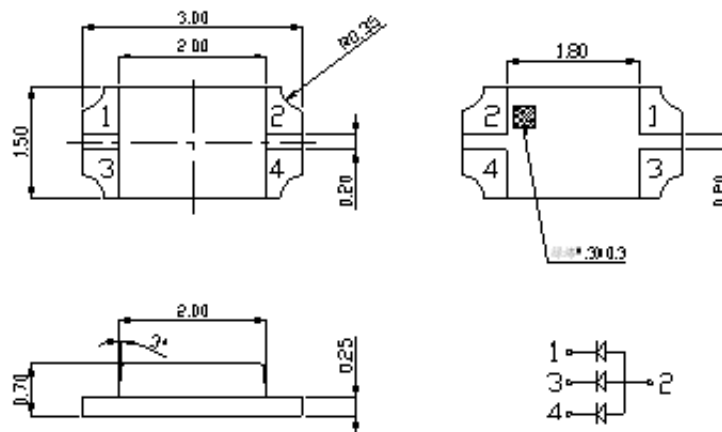

Notes:

- 1.All dimensions are in millimeters (inches).
- 2.Tolerance is ± 0.1 (0.004") unless otherwise noted.
- 3.Specifications are subject to change without notice.

Selection Guide

Part No.	Dice	Lens Type	Iv (mcd) @20mA		Viewing Angle
			Min.	Typ.	2 θ 1/2
BDS-1106SURZGQBC	Blue (InGaN)	Water Clear	50	100	120°
	Hyper Red (InGaAlP)		70	150	
	Green(InGaN)		70	200	

Note:

1. θ 1/2 is the angle from optical centerline where the luminous intensity is 1/2 the optical centerline value.

Electrical / Optical Characteristics at TA=25° C

Symbol	Parameter	Device	Typ.	Max.	Units	Test Conditions
λ peak	Peak Wavelength	Blue	465	/	nm	IF=20mA
		Hyper Red (InGaAlP)	630			
		Green	520			
λ D	Dominate Wavelength	Blue	470	/	nm	IF=20mA
		Hyper Red (InGaAlP)	621			
		Green	525			
$\Delta \lambda$ 1/2	Spectral Line Half-width	Blue	25	/	nm	IF=20mA
		Hyper Red (InGaAlP)	20			
		Green	38			
C	Capacitance	Blue	110	/	PF	VF=0V;f=1MHz
		Hyper Red (InGaAlP)	25			
		Green	40			
VF	Forward	Blue	3.1	3.4	V	IF=20mA
		Hyper Red (InGaAlP)	1.85	2.2		
		Green	2.9	3.4		
IR	Reverse Current	Blue	/	10	uA	VR=5V
		Hyper Red (InGaAlP)				
		Green				

Absolute Maximum Ratings at TA=25° C

Parameter	Blue	Hyper Red (InGaAlP)	Green	Units
Total Power dissipation (1)	350			mW
DC Forward Current	30	50	30	mA
Peak Forward Current (2)	150	195	150	mA
Reverse Voltage	5	5	5	V
Operating/Storage Temperature	-40° C To +85° C			

Note:

1. 1/10 Duty Cycle, 0.1ms Pulse Width.

Relative Intensity Vs Wavelength Chart

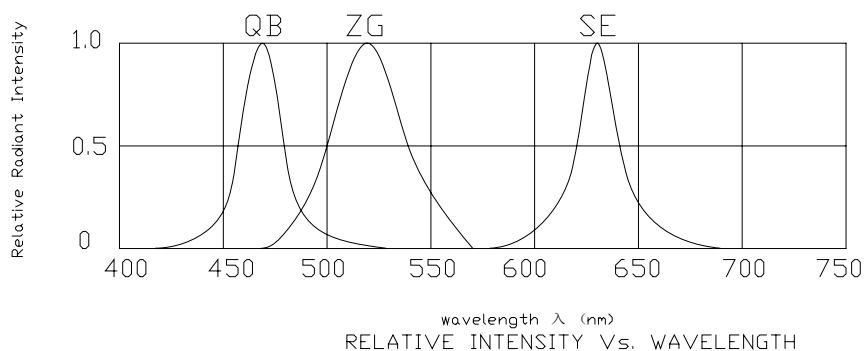

Full Color BDS-1106SURZGQBC

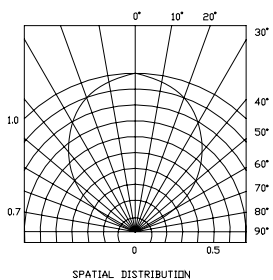
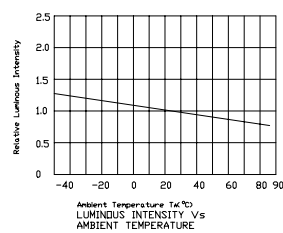
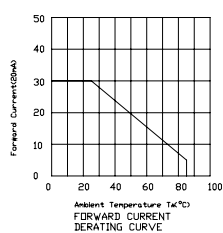
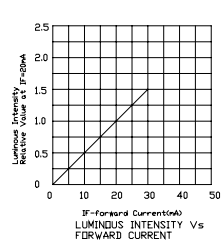
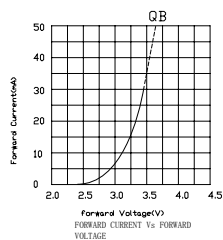
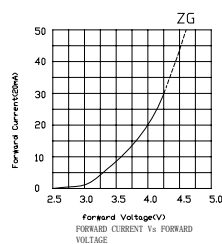
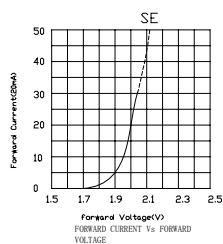

BDS-1106SURZGQBC
SMT Reflow Soldering Instructions

Number of reflow process shall be less than 2 times and cooling process to normal temperature is required between first and Second soldering process.

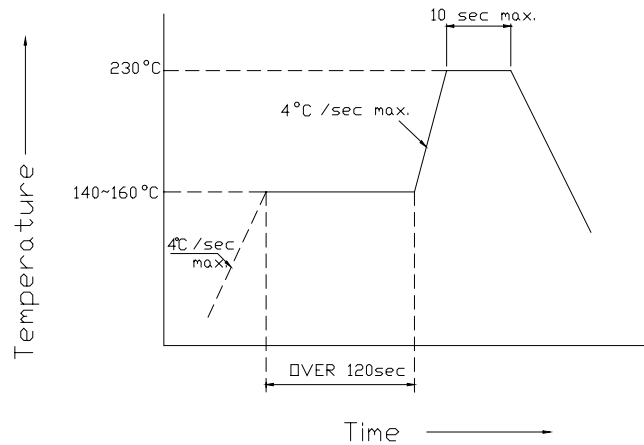

Recommended Soldering Pattern

<Units:mm>

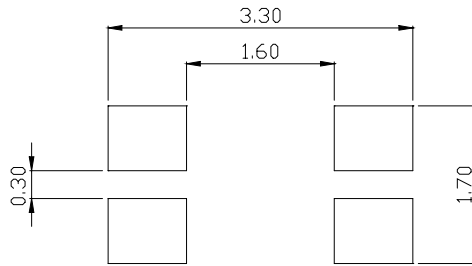

Tape Specifications

<Units:mm>

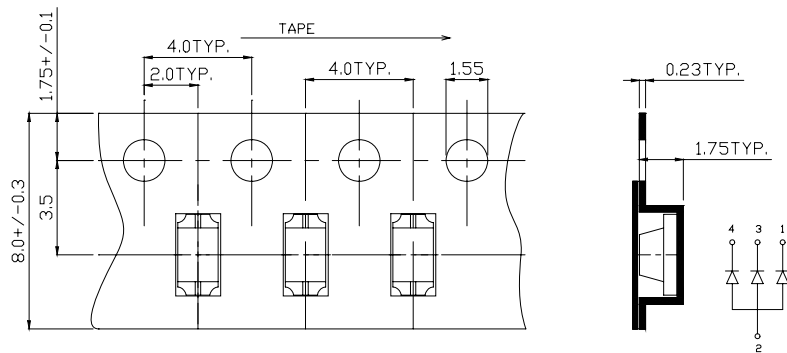

RELIABILITY**(1) TEST ITEMS AND RESULTS**

Test Item	Standard Test Method	Test Conditions	Note	Number of Damaged
Resistance to Soldering Heat (Reflow Soldering)	JEITA ED-4701 300 301	Tsld=260°C, 10sec. (Pre treatment 30°C,70%,168hrs)	2 times	0/50
Solderability (Reflow Soldering)	JEITA ED-4701 300 303	Tsld=215±5°C, 3sec. (Leader Solder)	1time over 95%	0/50
Thermal Shock	JEITA ED-4701 300 307	-40°C~100°C 5min. 5min.	100cycles	0/50
Temperature Cycle	JEITA ED-4701 100 105	-40°C~25°C~100°C~25°C 30min. 5min. 30min. 5min.	100cycles	0/50
Moisture Resistance Cycle	JEITA ED-4701 200 203	25°C~65°C~-10°C 90%RH 24hrs./1cycle	10 cycles	0/50
High Temperature Storage	JEITA ED-4701 200 201	Ta=100°C	1000 hrs	0/50
Temperature Humidity Storage	JEITA ED-4701 100 103	Ta=60°C, 90%RH	1000 hrs	0/50
Low Temperature Storage	JEITA ED-4701 200 202	Ta=-40°C	1000 hrs	0/50
Steady State Operating Life		Ta=25°C, IF=20mA	1000 hrs	0/50
Steady State Operating Life of High Temperature		Ta=85°C, IF=5mA	1000 hrs	0/50
Steady State Operating Life of High Humidity Heat		60°C, 90%RH, IF=15mA	500 hrs	0/50
Steady State Operating Life of Low Temperature		Ta=-30°C, IF=20mA	1000 hrs	0/50
Drop		H=75cm	3 cycles	0/50
Substrate Bending	JEITA ED-4702	3mm, 5 ± 1 sec.	1 time	0/50
Stick	JEITA ED-4702	5N, 10 ± 1 sec.	1 time	0/50

(2) CRITERIA FOR JUDGING THE DAMAGE

Item	Symbol	Test Conditions	Criteria for Judgement	
			Min.	Max.
Forward Voltage	V _F	I _F =20mA	-	U.S.L.*)X1.1
Reverse Current	I _R	V _R =5V	-	U.S.L.*)X2.0
Luminous Intensity	I _V	I _F =20mA	L.S.L.**))X0.9	-

*) U.S.L.: Upper Standard Level

**) L.S.L.: Lower Standard Level

Intensity Bin Limits (IF=20mA)

SELECTION CODE FOR SUPER BRIGHT LEDS		
Group	Light intensity in mcd(20mA) White	
	Min.	Max.
M	70	130
N	110	220
P	180	320
Q	280	420
R	380	550
S	480	750

Tolerance for each Bin limit is $\pm 10\%$.

(1) Color Bin Limits <IF=20mA>

Area (区域) Coordinate (座标)	A0	A01	B0	B1	C0
X	0.23-0.25	0.23-0.25	0.25-0.27	0.25-0.27	0.27-0.29
Y	0.21-0.24	0.24-0.27	0.23-0.26	0.26-0.29	0.25-0.28
Area (区域) Coordinate (座标)	C1	D0	D1	E0	E1
X	0.27-0.29	0.29-0.31	0.29-0.31	0.31-0.33	0.31-0.33
Y	0.28-0.31	0.27-0.30	0.30-0.33	0.29-0.32	0.32-0.35

Tolerance for each Bin limit is ± 0.01 .

Forward Voltage Bin limits(IF=20mA)

Grade (等级)	A	B	C	D	E	F	G	H	I	J
Range (范围)	1.7~1.9	1.9~2.1	2.1~2.3	2.3~2.5	2.7~2.9	2.9~3.1	3.1~3.3	3.3~3.5	3.5~3.7	3.7~3.9

Tolerance for each Bin limit is $\pm 0.1V$.