

SHENZHEN BOND OPTOELECTRONICS CO., LTD.

SPECIFICATION FOR APPROVAL

Customer: _____

Description: SMD LED

Model: BDS-1104QWC

No.: SD0017

Date: 2006-04-05

Enclosure is the specification

SHENZHEN BOND OPTOELECTRONICS CO., LTD.			
Production Dept.	Quality Dept.	Engineering Dept.	Marketing Dept.

APPROVED SIGNATURES			

Add: B501, Seat 5, YongLeXinCun, Nanshan District, Shenzhen, China

Tel: 0086-755-26685446

Fax: 0086-755-26822679

Email: Allen@bond-led.com

Website: <http://www.Bond-led.com>

Features

- 1)2.8mmx1.0mm SMT LED, 1.2mm THICKNESS.
- 2)LOW POWER CONSUMPTION.
- 3)WIDE SIDE VIEWING ANGLE.
- 4)IDEAL FOR BACKLIGHT.
- 5)VARIOUS COLORS AVAILABLE.
- 6)PACKAGE: 3000PCS/REEL.

Description

The White source color devices are made with GaN Light Emitting Diode.

Package Dimensions

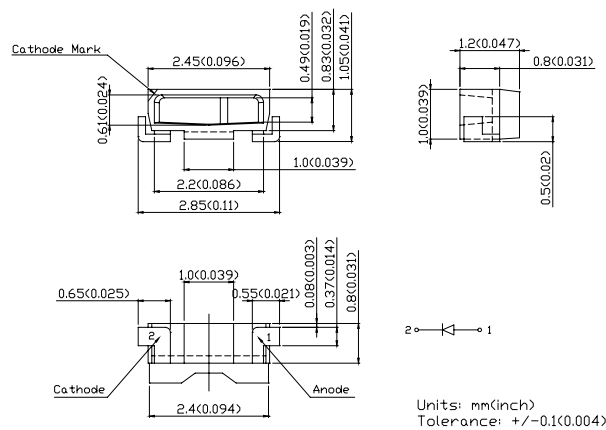

Notes:

- 1. All dimensions are in millimeters (inches).
- 2. Tolerance is ± 0.1 (0.004") unless otherwise noted.
- 3. Specifications are subject to change without notice.

Selection Guide

Part No.	Dice	Lens Type	Iv (mcd) @20mA		Viewing Angle
			Min.	Max.	2 θ 1/2
BDS-A1104QWC	White<GaN>	Water Clear	1100	1260	90°
			X=0.31-0.32, Y=0.31-0.32		

Note:

1. θ 1/2 is the angle from optical centerline where the luminous intensity is 1/2 the optical centerline value.

Electrical / Optical Characteristics at T_A=25° C

Symbol	Parameter	Device	Typ.	Max.	Units	Test Conditions
λ peak	Peak Wavelength	White	/	/	nm	IF=20mA
λ D	Dominate Wavelength	White	/	/	nm	IF=20mA
Δ λ 1/2	Spectral Line Half-width	White	/	/	nm	IF=20mA
C	Capacitance	White	65	/	PF	VF=0V;f=1MHz
VF	Forward	White	3.3	3.5	V	IF=20mA
IR	Reverse Current	White	/	10	uA	VR=5V

Absolute Maximum Ratings at T_A=25° C

Parameter	White	Units
Power dissipation	102	mW
DC Forward Current	30	mA
Peak Forward Current (1)	160	mA
Reverse Voltage	5	V
Operating/Storage Temperature	-40° C To +85° C	

Note:

1. 1/10 Duty Cycle, 0.1ms Pulse Width.

White BDS-1104QWC

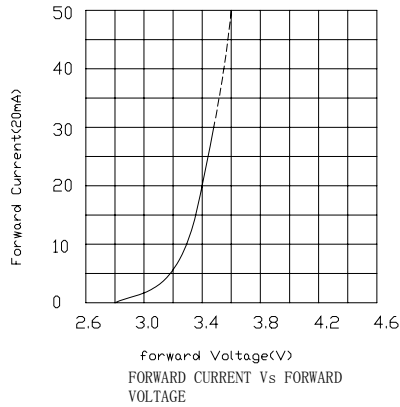

正向电流与正向电压关系曲线图

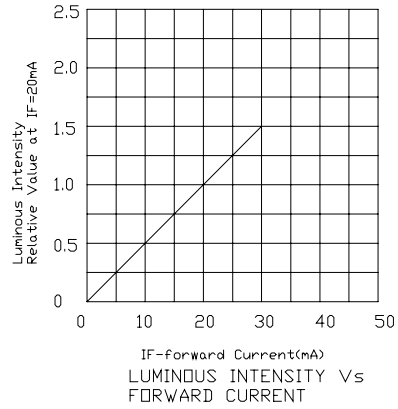

亮度与正向电流关系曲线图

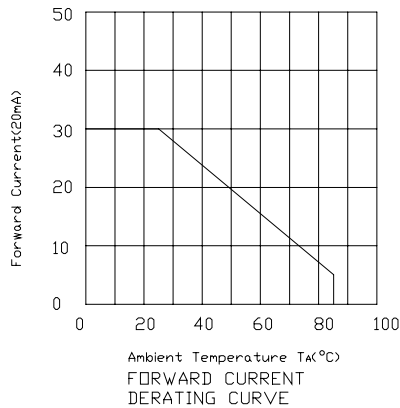

正向电流递减曲线图

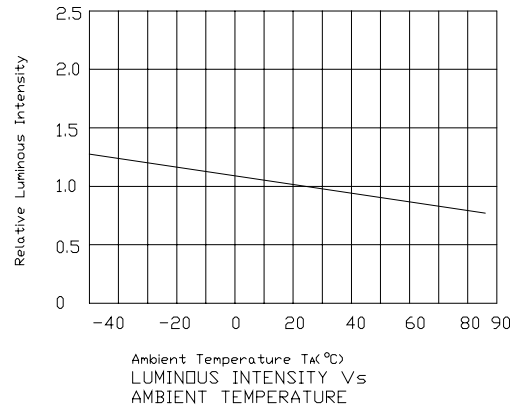

亮度与环境温度关系曲线图

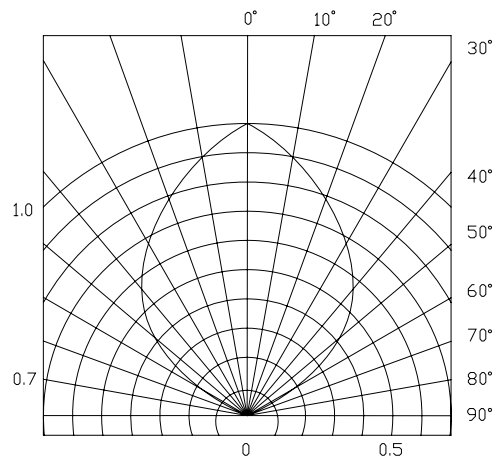

SPATIAL DISTRIBUTION

发光角度图解

BDS-1104QWC
SMT Reflow Soldering Instructions

Number of reflow process shall be less than 2 times and cooling process to normal temperature is required between first and Second soldering process.

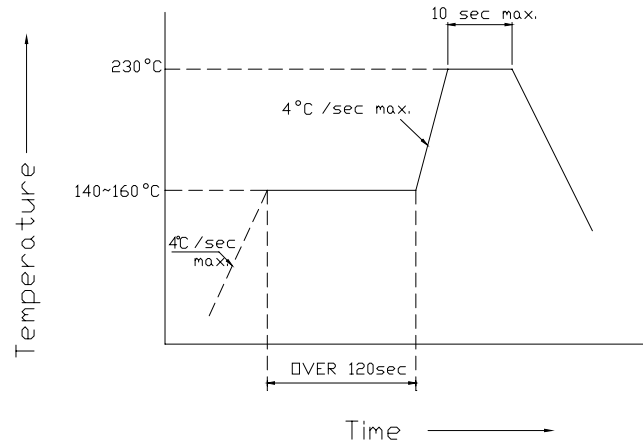

Recommended Soldering Pattern

<Units:mm>

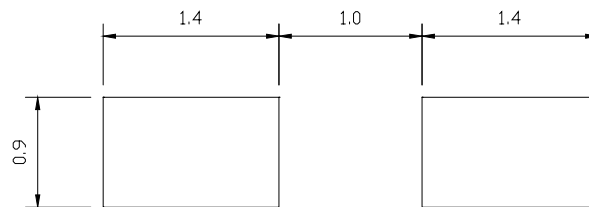

Tape Specifications

<Units:mm>

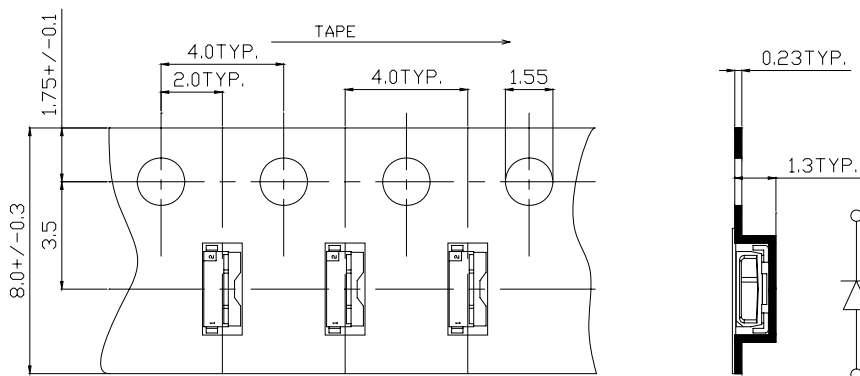

RELIABILITY**(1) TEST ITEMS AND RESULTS**

Test Item	Standard Test Method	Test Conditions	Note	Number of Damaged
Resistance to Soldering Heat (Reflow Soldering)	JEITA ED-4701 300 301	Tsld=260°C, 10sec. (Pre treatment 30°C,70%,168hrs)	2 times	0/50
Solderability (Reflow Soldering)	JEITA ED-4701 300 303	Tsld=215±5°C, 3sec. (Leader Solder)	1time over 95%	0/50
Thermal Shock	JEITA ED-4701 300 307	-40°C~100°C 5min. 5min.	100cycles	0/50
Temperature Cycle	JEITA ED-4701 100 105	-40°C~25°C~100°C~25°C 30min. 5min. 30min. 5min.	100cycles	0/50
Moisture Resistance Cycle	JEITA ED-4701 200 203	25°C~65°C~-10°C 90%RH 24hrs./1cycle	10 cycles	0/50
High Temperature Storage	JEITA ED-4701 200 201	Ta=100°C	1000 hrs	0/50
Temperature Humidity Storage	JEITA ED-4701 100 103	Ta=60°C, 90%RH	1000 hrs	0/50
Low Temperature Storage	JEITA ED-4701 200 202	Ta=-40°C	1000 hrs	0/50
Steady State Operating Life		Ta=25°C, IF=20mA	1000 hrs	0/50
Steady State Operating Life of High Temperature		Ta=85°C, IF=5mA	1000 hrs	0/50
Steady State Operating Life of High Humidity Heat		60°C, 90%RH, IF=20MA	500 hrs	0/50
Steady State Operating Life of Low Temperature		Ta=-30°C, IF=20mA	1000 hrs	0/50
Drop		H=75cm	3 cycles	0/50
Substrate Bending	JEITA ED-4702	3mm, 5 ± 1 sec.	1 time	0/50
Stick	JEITA ED-4702	5N, 10 ± 1 sec.	1 time	0/50

(2) CRITERIA FOR JUDGING THE DAMAGE

Item	Symbol	Test Conditions	Criteria for Judgement	
			Min.	Max.
Forward Voltage	V _F	I _F =20mA	-	U.S.L.*)X1.1
Reverse Current	I _R	V _R =5V	-	U.S.L.*)X2.0
Luminous Intensity	I _V	I _F =20mA	L.S.L.**))X0.7	-

*) U.S.L.: Upper Standard Level

**) L.S.L.: Lower Standard Level

Intensity And Color Bin Limits

(1) Intensity Bin Limits (IF=20mA)

SELECTION CODE FOR SUPER BRIGHT LEDS		
Group	Light intensity in mcd(20mA) Super Bright Red	
	Min.	Max.
S	480	750
T	650	110
U	900	1500
V	1200	1800
W	1500	2100
X	1800	2500

Tolerance for each Bin limit is ± 0.15 .

(2) Color Bin Limits <IF=20mA>

Coordinate \ Area	A0	A1	B0	B1	C0
	X	0.23-0.25	0.23-0.25	0.25-0.27	0.25-0.27
Y	0.21-0.24	0.24-0.27	0.23-0.26	0.26-0.29	0.25-0.28
Coordinate \ Area	C1	D0	D1	E0	E1
	X	0.27-0.29	0.29-0.31	0.29-0.31	0.31-0.33
Y	0.28-0.31	0.27-0.30	0.30-0.33	0.29-0.32	0.32-0.35

Tolerance for each Bin limit is ± 0.01 .

Forward Voltage Bin limits(IF=20mA)

Grade	A	B	C	D	E	F	G	H	I	J
Range	1.7~1.9	1.9~2.1	2.1~2.3	2.3~2.5	2.7~2.9	2.9~3.1	3.1~3.3	3.3~3.5	3.5~3.7	3.7~3.9