

SHENZHEN BOND OPTOELECTRONICS CO.,LTD

SPECIFICATION FOR APPROVAL

Customer: _____

Description: _____ SMD LED _____

Model: _____ BDS-1206QWC _____

No.: _____ SD0009 _____

Date: _____ 2006-03-24 _____

Enclosure is the specification

SHENZHEN BOND OPTOELECTRONICS CO.,LTD			
Production Dept.	Quality Dept.	Engineering Dept.	Marketing Dept.

APPROVED SIGNATURES			

Address: B501, Seat 5, YongLeXinCun, Nanshan District, Shenzhen, China

电话 Tel: 0086-755-26685446

传真 Fax: 0086-755-26685446

E-mail: kevin@bond-led.com

Website: <http://www.bond-led.com>

BDS-1206QWC White**Features**

- 1)3.2mmx1.6mm SMT LED, 0.75mm THICKNESS.
- 2)LOW POWER CONSUMPTION.
- 3)WIDE VIEWING ANGLE.
- 4)IDEAL FOR BACKLIGHT AND INDICATOR.
- 5)VARIOUS COLORS AND LENS TYPES AVAILABLE.
- 6)PACKAGE: 3000PCS/REEL.

Description

The White source color devices are made with GaN Light Emitting Diode.

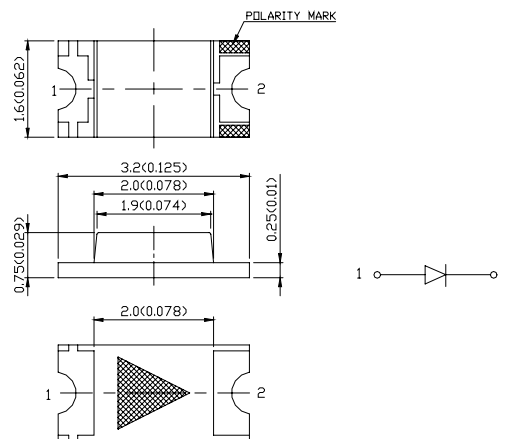
Package Dimensions**Notes:**

1. All dimensions are in millimeters (inches).
2. Tolerance is ± 0.1 (0.004") unless otherwise noted.
3. Specifications are subject to change without notice.

Selection Guide

Part No.	Dice	Lens Type	Iv (mcd) @20mA		Viewing Angle
			Min.	Max.	2 θ 1/2
BDS-1206QWC	White <GaN>	Water Clear	750	1000	120°
			X=0.30,Y=0.31		

Note:

1. θ 1/2 is the angle from optical centerline where the luminous intensity is 1/2 the optical centerline value.

Electrical / Optical Characteristics at TA=25° C

Symbol	Parameter	Device	Typ.	Max.	Units	Test Conditions
λ peak	Peak Wavelength	White	-	-	nm	I _F =20mA
λ D	Dominate Wavelength	White	-	-	nm	I _F =20mA
$\Delta \lambda$ 1/2	Spectral Line Half-width	White	-	-	nm	I _F =20mA
C	Capacitance	White	65	-	P _F	V _F =0V;f=1MHz
V _F	Forward	White	3.1	3.5	V	I _F =20mA
I _R	Reverse Current	White	-	10	uA	V _R =5V

Absolute Maximum Ratings at TA=25° C

Parameter	White	Units
Power dissipation	105	mW
DC Forward Current	30	mA
Peak Forward Current (1)	150	mA
Reverse Voltage	5	V
Operating/Storage Temperature	-40° C To +85° C	

Note:

1. 1/10 Duty Cycle, 0.1ms Pulse Width.

White BDS-1206QWC

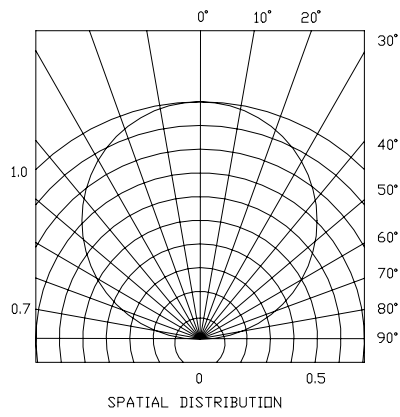
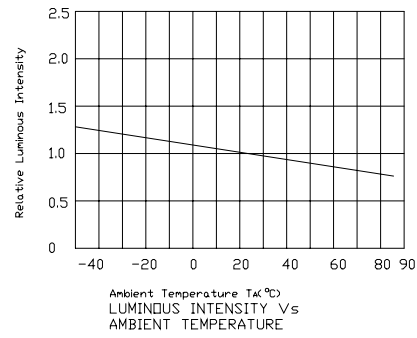
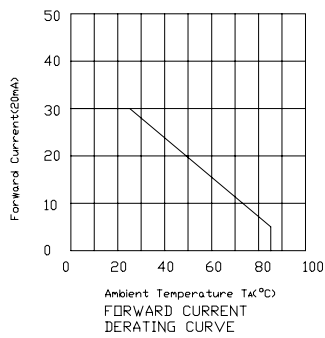
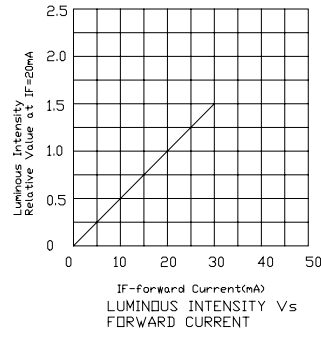
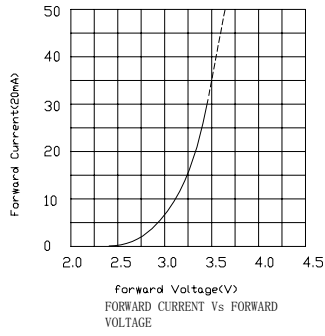

BDS-1206QWC
SMT Reflow Soldering Instructions

Number of reflow process shall be less than 2 times and cooling process to normal temperature is required between first and Second soldering process.

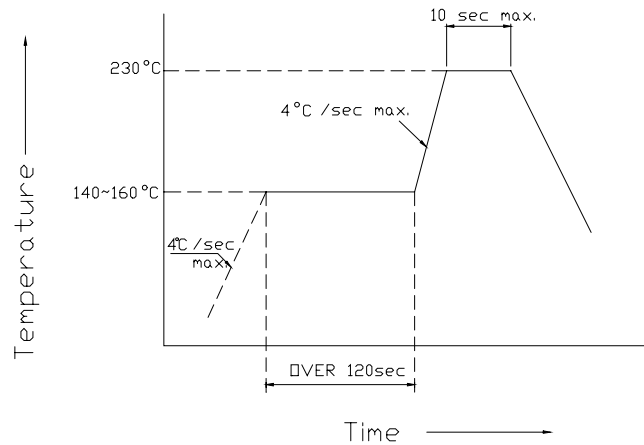

Recommended Soldering Pattern

<Units:mm>

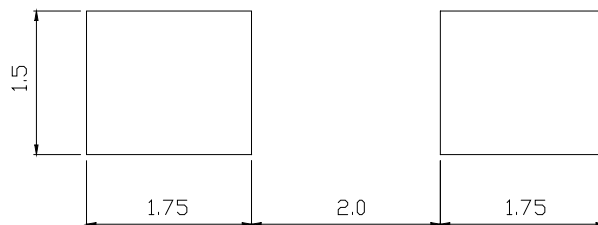

Tape Specifications

<Units:mm>

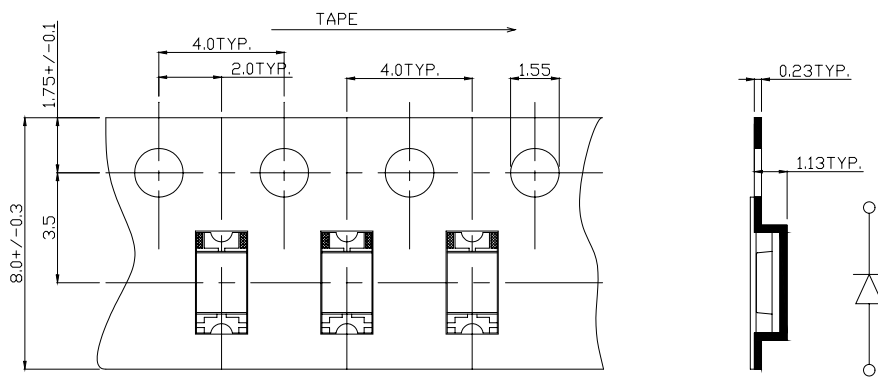

RELIABILITY**(1) TEST ITEMS AND RESULTS**

Test Item	Standard Test Method	Test Conditions	Note	Number of Damaged
Resistance to Soldering Heat (Reflow Soldering)	JEITA ED-4701 300 301	Tsld=260°C, 10sec. (Pre treatment 30°C,70%,168hrs)	2 times	0/50
Solderability (Reflow Soldering)	JEITA ED-4701 300 303	Tsld=215±5°C, 3sec. (Leader Solder)	1time over 95%	0/50
Thermal Shock	JEITA ED-4701 300 307	-40°C~100°C 5min. 5min.	100cycles	0/50
Temperature Cycle	JEITA ED-4701 100 105	-40°C~25°C~100°C~25°C 30min. 5min. 30min. 5min.	100cycles	0/50
Moisture Resistance Cycle	JEITA ED-4701 200 203	25°C~65°C~-10°C 90%RH 24hrs./1cycle	10 cycles	0/50
High Temperature Storage	JEITA ED-4701 200 201	Ta=100°C	1000 hrs	0/50
Temperature Humidity Storage	JEITA ED-4701 100 103	Ta=60°C, 90%RH	1000 hrs	0/50
Low Temperature Storage	JEITA ED-4701 200 202	Ta=-40°C	1000 hrs	0/50
Steady State Operating Life		Ta=25°C, IF=20mA	1000 hrs	0/50
Steady State Operating Life of High Temperature		Ta=85°C, IF=5mA	1000 hrs	0/50
Steady State Operating Life of High Humidity Heat		60°C, 90%RH, IF=15mA	500 hrs	0/50
Steady State Operating Life of Low Temperature		Ta=-30°C, IF=20mA	1000 hrs	0/50
Drop		H=75cm	3 cycles	0/50
Substrate Bending	JEITA ED-4702	3mm, 5 ± 1 sec.	1 time	0/50
Stick	JEITA ED-4702	5N, 10 ± 1 sec.	1 time	0/50

(2) CRITERIA FOR JUDGING THE DAMAGE

Item	Symbol	Test Conditions	Criteria for Judgement	
			Min.	Max.
Forward Voltage	V _F	I _F =20mA	-	U.S.L.*)X1.1
Reverse Current	I _R	V _R =5V	-	U.S.L.*)X2.0
Luminous Intensity	I _V	I _F =20mA	L.S.L.***)X0.7	-

*) U.S.L.: Upper Standard Level

**) L.S.L.: Lower Standard Level

Intensity And Color Bin Limits

(1) Intensity Bin Limits ($I_F=20mA$)

SELECTION CODE FOR SUPER BRIGHT LEDS		
Group	Light intensity in mcd(20mA)	
	min.	max.
N	110	220
P	180	320
Q	280	420
R	380	550
S	480	750

Tolerance for each Bin limit is ± 0.15 .

(2) Color Bin Limits $\langle I_F=20mA \rangle$

Coordinate \ Area	Area	A0	A1	B0	B1	C0
	X	0.23-0.25	0.23-0.25	0.25-0.27	0.25-0.27	0.27-0.29
Y	0.21-0.24	0.24-0.27	0.23-0.26	0.26-0.29	0.25-0.28	
Coordinate \ Area	Area	C1	D0	D1	E0	E1
	X	0.27-0.29	0.29-0.31	0.29-0.31	0.31-0.33	0.31-0.33
Y	0.28-0.31	0.27-0.30	0.30-0.33	0.29-0.32	0.32-0.35	

Tolerance for each Bin limit is ± 0.01 .

Forward Voltage Bin limits($I_F=20mA$)

Grade	A	B	C	D	E	F	G	H	I	J
Range	1.7~1.9	1.9~2.1	2.1~2.3	2.3~2.5	2.7~2.9	2.9~3.1	3.1~3.3	3.3~3.5	3.5~3.7	3.7~3.9

Tolerance for each Bin limit is ± 0.05 .