

SHENZHEN BOND OPTOELECTRONICS CO.,LTD

SPECIFICATION FOR APPROVAL

Customer: _____

Description: _____ SMD LED _____

Model: _____ BDS-0805SURC _____

No.: _____ SD0006 _____

Date: _____ 2006.03.23 _____

Enclosure is the specification

SHENZHEN BOND OPTOELECTRONICS CO.,LTD			
Production Dept.	Quality Dept.	Engineering Dept.	Marketing Dept.

APPROVED SIGNATURES			

Address: B501, Seat 5, YongLeXinCun, Nanshan District, Shenzhen, China

Tel: 0086-755-26685446

Fax: 0086-755-26822679

E-mail: Allen@bond-led.com

Website: <http://www.bond-led.com>

BDS-0805SURC HYPER RED**Features**

- 1)2.0mmx1.25mm SMT LED, 0.7mm THICKNESS.
- 2)LOW POWER CONSUMPTION.
- 3)WIDE VIEWING ANGLE.
- 4)IDEAL FOR BACKLIGHT AND INDICATOR.
- 5)VARIOUS COLORS AND LENS TYPES AVAILABLE.
- 6)PACKAGE: 3000PCS/REEL.

Description

The Blue source color devices are made with GaN Light Emitting Diode.

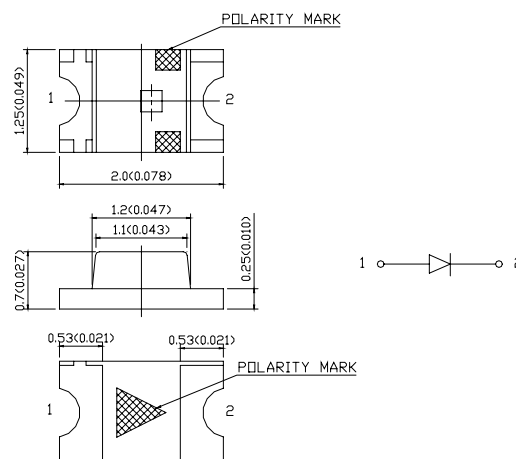
Package Dimensions**Notes:**

1. All dimensions are in millimeters (inches).
2. Tolerance is ± 0.1 (0.004") unless otherwise noted.
3. Specifications are subject to change without notice.

Selection Guide

Part No.	Dice	Lens Type	Iv (mcd) @20mA		Viewing Angle
			Min.	Typ.	2 θ 1/2
BDS-0805SURC	Hyper Red <InGaAlP>	Water Clear	180	320	120°

Note:

1. θ 1/2 is the angle from optical centerline where the luminous intensity is 1/2 the optical centerline value.

Electrical / Optical Characteristics at TA=25° C

Symbol	Parameter	Device	Typ.	Max.	Units	Test Conditions
λ peak	Peak Wavelength	HYPER RED	630	-	nm	I _F =20mA
λ D	Dominate Wavelength	HYPER RED	620	630	nm	I _F =20mA
$\Delta \lambda$ 1/2	Spectral Line Half-width	HYPER RED	27	-	nm	I _F =20mA
C	Capacitance	HYPER RED	45	-	P _F	V _F =0V;f=1MHz
V _F	Forward	HYPER RED	2.0	2.3	V	I _F =20mA
I _R	Reverse Current	HYPER RED	-	10	uA	V _R =5V

Absolute Maximum Ratings at TA=25° C

Parameter	HYPER RED	Units
Power dissipation	170	mW
DC Forward Current	30	mA
Peak Forward Current (1)	150	mA
Reverse Voltage	5	V
Operating/Storage Temperature	-40° C To +85° C	

Note:

1. 1/10 Duty Cycle, 0.1ms Pulse Width.

Relative Intensity Vs Wavelength Chart

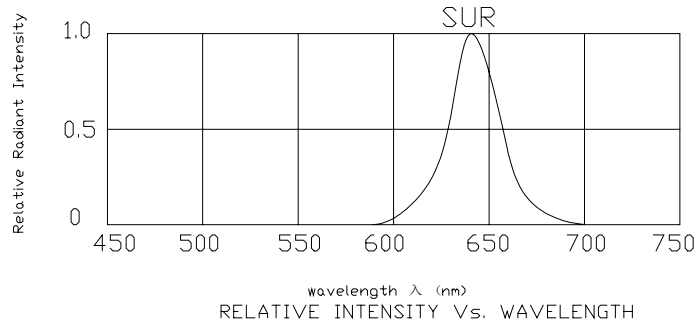

Blue BDS-0805SURC

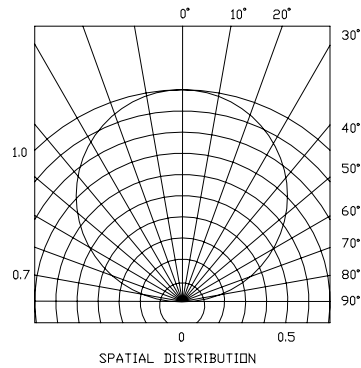
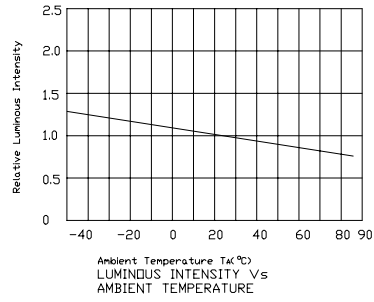
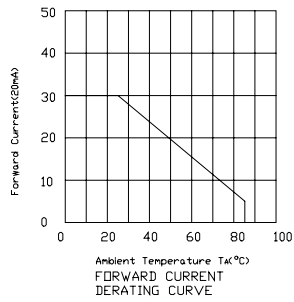
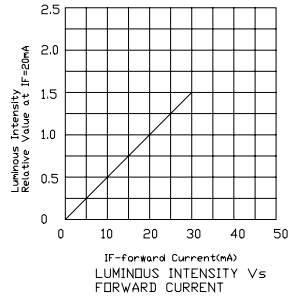
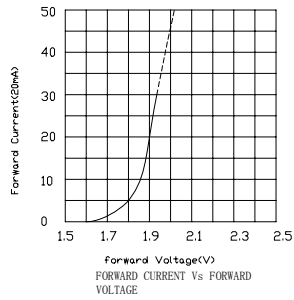

BDS-0805SURC

SMT Reflow Soldering Instructions

Number of reflow process shall be less than 2 times and cooling process to normal temperature is required between first and Second soldering process.

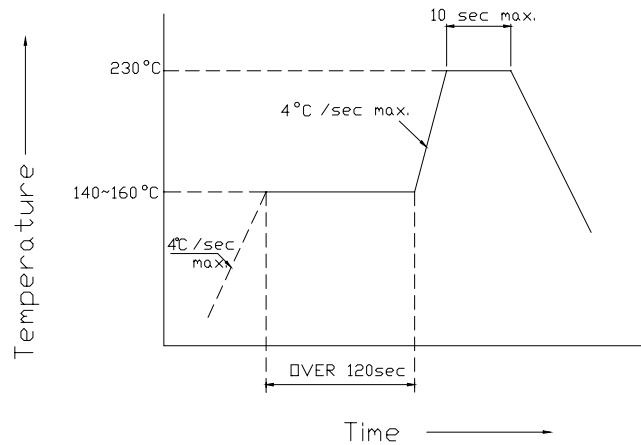

Recommended Soldering Pattern

<Units:mm>

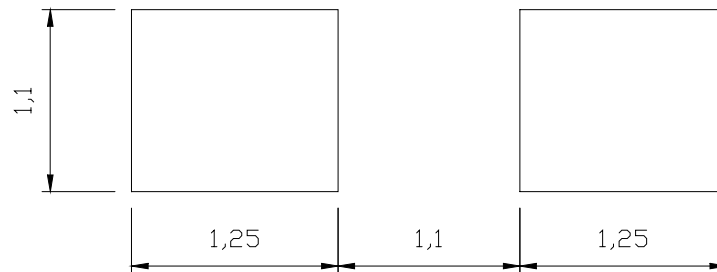

Tape Specifications

<Units:mm>

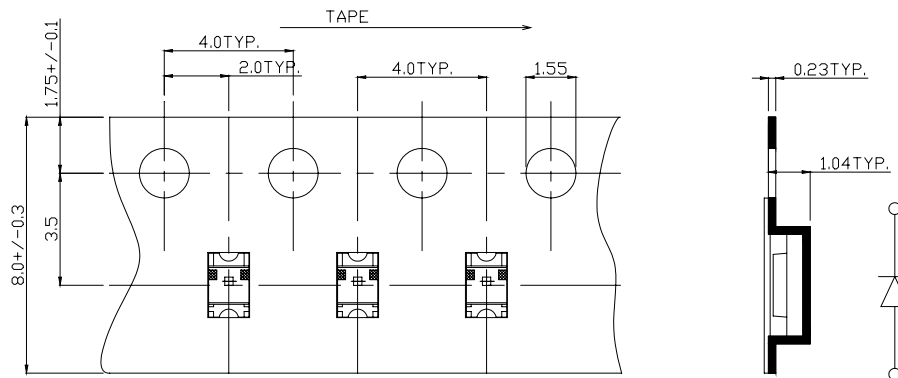

RELIABILITY**TEST ITEMS AND RESULTS**

Test Item	Standard Test Method	Test Conditions	Note	Number of Damaged
Resistance to Soldering Heat (Reflow Soldering)	JEITA ED-4701 300 301	Tsld=260°C, 10sec. (Pre treatment 30°C,70%,168hrs)	2 times	0/50
Solderability (Reflow Soldering)	JEITA ED-4701 300 303	Tsld=215±5°C, 3sec. (Leader Solder)	1time over 95%	0/50
Thermal Shock	JEITA ED-4701 300 307	-40°C~100°C 5min. 5min.	100cycles	0/50
Temperature Cycle	JEITA ED-4701 100 105	-40°C~25°C~100°C~25°C 30min. 5min. 30min. 5min.	100cycles	0/50
Moisture Resistance Cycle	JEITA ED-4701 200 203	25°C~65°C~-10°C 90%RH 24hrs./1cycle	10 cycles	0/50
High Temperature Storage	JEITA ED-4701 200 201	Ta=100°C	1000 hrs	0/50
Temperature Humidity Storage	JEITA ED-4701 100 103	Ta=60°C, 90%RH	1000 hrs	0/50
Low Temperature Storage	JEITA ED-4701 200 202	Ta=-40°C	1000 hrs	0/50
Steady State Operating Life		Ta=25°C, IF=20mA	1000 hrs	0/50
Steady State Operating Life of High Temperature		Ta=85°C, IF=5mA	1000 hrs	0/50
Steady State Operating Life of High Humidity Heat		60°C, 90%RH, IF=15mA	500 hrs	0/50
Steady State Operating Life of Low Temperature		Ta=-30°C, IF=20mA	1000 hrs	0/50
Drop		H=75cm	3 cycles	0/50
Substrate Bending	JEITA ED-4702	3mm, 5 ± 1 sec.	1 time	0/50
Stick	JEITA ED-4702	5N, 10 ± 1 sec.	1 time	0/50

(2) CRITERIA FOR JUDGING THE DAMAGE

Item	Symbol	Test Conditions	Criteria for Judgement	
			Min.	Max.
Forward Voltage	V _F	I _F =20mA	-	U.S.L.*)X1.1
Reverse Current	I _R	V _R =5V	-	U.S.L.*)X2.0
Luminous Intensity	I _V	I _F =20mA	L.S.L.***)X0.7	-

*) U.S.L.: Upper Standard Level

**) L.S.L.: Lower Standard Level

Intensity And Color Bin Limits**(1) Intensity Bin Limits (I_F=20mA)**

SELECTION CODE FOR SUPER BRIGHT LEDS		
Group	Light intensity in mcd(20mA) Hyper Red	
	Min.	Max.
H	50	90
M	70	130
N	110	220
P	180	320
Q	280	420

Tolerance for each Bin limit is ± 0.15 .

(2) Color Bin Limits (I_F=20mA)

COLOR CODE FOR RED LEDS + DISPLAYS		
Group	Dom. WaveLength (nm)	
	min.	max.
1	600	610
2	610	620
3	620	630
4	630	640
5	640	650

Tolerance for each Bin limit is ± 0.15 .

Forward Voltage Bin limits(I_F=20mA)

Grade	A	B	C	D	E	F	G	H	I	J
Range	1.7~1.9	1.9~2.1	2.1~2.3	2.3~2.5	2.7~2.9	2.9~3.1	3.1~3.3	3.3~3.5	3.5~3.7	3.7~3.9

Tolerance for each Bin limit is ± 0.05 .